



De-Icer Owners Manual



Contents

Safety Instructions2
Unit Specs2
De-Icer Sizing Chart2
General Owner's Instructions2
De-Icer Installation Instructions3
Warranty Policy5
Maintenance Recommendations6
Troubleshooting Tips7
Replacement Parts Diagram9
Additional Accessories for Your De-Icer10
Customer Repair Form11
Registration Information12



3020379
ANSI/UL 778, 5th Ed. 2010
CAN/CSA C22.2 No. 108-M89
UL 50, 11th Ed. 1995

Kasco Marine, Inc.
800 Deere Rd.
Prescott, WI 54021
U.S.A.
Phone 715-262-4488
Fax 715-262-4487
sales@kascomarine.com
www.kascomarine.com

824404
Rev. 05/22/12

Safety Instructions



CAUTION

- Under NO circumstances should anyone enter the water with the electrical equipment connected and/or in operation. It is NEVER recommended to enter the water with the equipment in operation.
- Caution should be used when dealing with any electrical equipment with moving parts.
- NEVER run the unit out of water. It will damage the seals and create a dangerous situation for the operator.
- Extreme caution should be used around water, especially cold water, such as in Spring, Fall, and Winter, which poses a hazard in and of itself.
- NEVER lift or drag the unit by the power or light cord. If you need to pull the unit to the side of the pond, use the anchoring ropes.
- Do not use waders in deep ponds/lakes or ponds/lakes with drop-offs, drastic slopes, or soft bottom material.
- Do not use boats that tip easily for unit installation, such as a canoe, and follow all boating safety rules and regulations, including wearing a PFD. (Personal Flotation Device)
- The unit is supplied with an internal grounding conductor. To reduce the risk of electrical shock, be certain that the unit is plugged/connected to an approved GFCI protected circuit.
- Means for disconnection must be incorporated in the fixed wiring in accordance with local and national wiring rules.
- Consult a qualified electrician for electrical installation.



Note: Under certain conditions, no de-icer can prevent damage from ice movement caused by wind or current, or from extremely cold weather.

Unit Specs

Model	Voltage	Operating amps	lock rotor amps
2400D	110-120	5.0	12
3400D	110-120	6.7	18
3400HD	208-240	3.4	9
4400D	110-120	11.3	40
4400HD	208-240	5.7	20

De-Icer Sizing Chart

Avg. Low Air Temp	Orientation	Model		
		2400	3400	4400
34 ^o to 20 ^o F	angled	30' x 100'	35' x 120'	40' x 150'
	vertical	65'	85'	95'
19 ^o to 0 ^o F	angled	25' x 60'	30' x 80'	34' x 90'
	vertical	50'	70'	80'
-1 ^o to 20 ^o F	angled	25' x 50'	30' x 75'	35' x 85'
	vertical	45'	65'	75'
Great Lakes	angled	20' x 40'	25' x 50'	30' x 60'
	vertical	35'	45'	55'

Assumptions for chart:

- Unobstructed water
 - 200 acre plus body of water with 200 ft plus maximum water depth or greater
 - Water depth in de-icing area 4 ft plus
- (Size may vary greatly based on a number of local conditions)

General Owner's Instructions

INSPECT THE SHIPMENT

Immediately inspect your Kasco De-Icer shipment for any visible damages. Also cross reference the parts supplied with the Parts Included sheet to check for shortages. Shortages should be reported immediately to your Kasco Marine distributor or representative and damages reported to your carrier and Kasco Marine.

CAUTION

WARNING: Under NO circumstances should anyone enter the water with the unit in operation. Always operate the unit in the water and keep people and objects clear of the propeller. Do not lift or pull the unit by the electrical cord. Always use extreme caution around electrical equipment and water situations.

ASSEMBLY & INSTALLATION

Please see the proper Assembly and Installation Instructions enclosed in this manual. Each is specific for your model and size of De-Icer and De-Icer accessory.

WARRANTY

Kasco De-Icers are the result of over 40 years of design and engineering. Kasco products are built to withstand the toughest conditions. Kasco Marine backs each De-Icer with a 2 Year Warranty. This warranty covers any and all manufacturers defects within 2 years from the date of purchase (See Warranty Policy). Please register your De-Icer online at: www.de-icer.com/solutions_warranty_registration.htm.

USE AND OPERATION

Kasco De-Icers are designed and engineered for continuous duty in the harshest environments, such as in marinas or other commercial applications, or on-demand use, as may be needed.

Your Kasco Marine De-Icer is ready for immediate use (after installation). The motor is of an oil-filled design with ball bearings submerged in oil and equipped with a thermal overload protection with an automatic reset. No further lubrication is necessary. It is extremely important that the installer make sure sufficient and proper voltage is available to the unit's motor. The zinc anode located below the propeller must be in good condition in order to prevent corrosion damage to the unit. The zinc anode must be inspected periodically and replaced if it shows significant deterioration. Make sure to keep the motor housing clean from hard water deposits and/or algae. (See Maintenance Recommendations on page 6.)



Note: If the De-Icer has been stored or exposed to cold for an extended period without running, it may take a minute for the prop to get to full speed once power is supplied.

The De-Icer is also completely assembled, you do not need bolts, screws, nails, or brackets, unless an optional mounting device was purchased. All you have to do is suspend it in as little as two (2) feet of water from piers, docks, or boats and plug it into a properly grounded and GFI protected 15 amp outlet.

Kasco De-Icers are lightweight, energy efficient, and

easy to install and operate. We strive to produce products that exceed customer expectations. We hope you enjoy your Kasco De-Icer.

Please Note: Under certain conditions, no de-icer can prevent damage from ice movement caused by wind or current, or from extremely cold weather causing ice to form all the way to the bottom and in some cases where bottom water temperature is the same as the ice. Effective de-icing can also be retarded when used in extremely shallow conditions.

UNIT STORAGE

When storing units during the offseason, it is important to store them upside down if they are going to be sitting for long periods of time. Units that sit upright on a shelf for many months, or even years have a greater likelihood of seals drying out. Storing upside down will ensure oil is lubricating the seals and prevent drying.

De-Icer Installation Instructions

Kasco offers three basic ways for De-Icer installation: Vertical Rope Suspension, Universal Dock Mounting kit, or Angled / Horizontal Float Installation. Different De-Icing objectives may require different mounting/installation options.

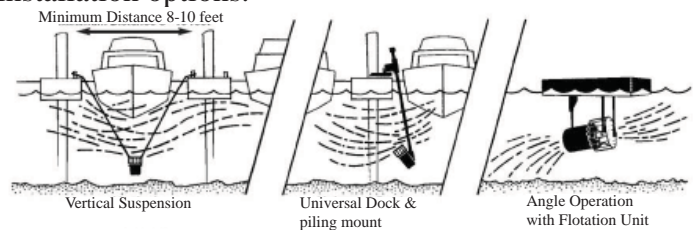

STEP ONE

Locating a De-Icer depends on your De-Icing objectives. If ice expansion pressure is your concern, you may find it easier to have an open-water buffer between your dock or structure and the expanding ice pack.

If ice lifting or a combination of lifting/expansion is your concern, you may wish to keep your dock, structure, or boat area completely ice free. These objectives are different and may require different installations.

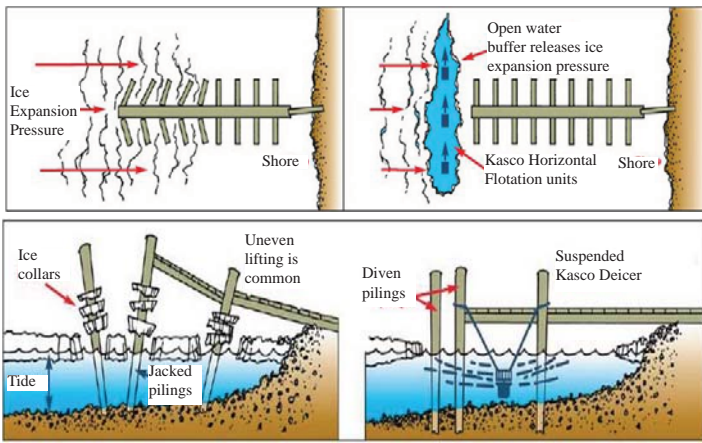

you can choose your installation point(s). Some useful tricks you may wish to consider are:

- De-Ice from the upstream side and let the current help, rather than hinder.
- Boats are designed to allow water to flow from the bow to the stern with the least resistance. It is generally easier to De-Ice a boat by installing the De-Icer at or near the bow, angled to push the De-Icing flow of water toward the stern.
- It is generally easier to De-Ice a shallow area by bringing the warmer water from a deeper area into the shallow water. Angle your De-Icer from the deeper water toward the shallow water.
- When using more than one unit, it is better to angle all units in one direction, creating a current rather than installing De-Icers in opposing directions.
- In tidal waters, split the difference in water depth so the De-Icer is in shallow water at low tide and deep water at high tide. If you are De-Icing a boat, it is easier to tie your De-Icer to the boat and allow the boat and De-Icer to rise and fall with the tide together.

STEP TWO

Determine the best location(s) to install. A De-Icer draws warmer, denser water from the bottom (4°C is approximately water's densest point) and circulates it upward to the surface. Around docks and boats water is usually fairly shallow, so look for somewhat deep water to install your De-Icer. However, if your De-Icer is installed too deep, the rising warmer water will not effectively spread at the surface, thereby reducing the De-Icing effect.

 Note: A good guide is 4-6 feet deep for vertical installation, and slightly shallower for angled operation, but at least 1 foot off the bottom to prevent clogging from debris. In colder climates, warmer water is a more important factor than surface circulation, so you may wish to install your De-Icer deeper than the above guide lines. De-Icers generally will work in shallower water, but are less effective and due to the constraints of your installation, you may have to settle for a shallower installation. It is recommended that you experiment with more than one possible location for the best installation results.

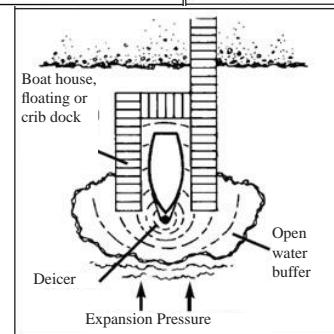
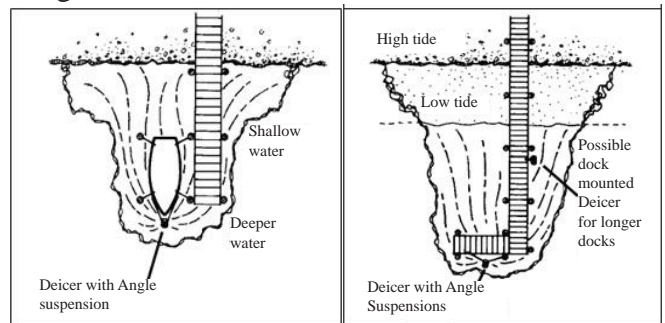

STEP THREE

When you have determined both your De-Icing objectives and best installation points, it is time to analyze what external constraints your De-Icing location (structures, i.e., dock, boat, etc.) may have that could affect the flow of warmer water at the surface. Any obstruction at the surface of the water may slow or stop the flow of warmer water. A natural current, such as in a river, will tend to force your De-Icing efforts downstream. Once you have determined your external constraints,

STEP FOUR

When installing your Kasco De-Icer for suspended operation with the provided ropes, make sure the ropes or suspension lines are spread at least 8 to 10 feet apart. The high starting torque of your Kasco De-Icer may cause suspension lines that are too close together to twist up and possibly damage the electrical power cord. Tie each rope with a secure knot from the dock piling, cleat, boat etc. so the De-Icer hangs vertically.

Angling your Kasco De-Icer with suspension operation can be accomplished easily by simply changing the mounting location of one suspension line. There is no need to remove the knot and splice of the rope, simply change the point at which the line leaves the propeller cage by looping the rope around the top circular band over 1 to 4 vertical cage wires (more than 4 not recommended). This will move the support lines off center and allow the unit to hang at a slight angle. After installation and the unit is turned on, your Kasco De-Icer will swing up to an angle (the angle is dependent on how many cage wires you move the line) and the De-Icer will hold that angle during operation. This allows you to aim the flow of warmer water in the desired location. If the Universal Dock Mount or Horizontal Float were purchased, see their Assembly and Installation Instructions.

STEP FIVE

Once your De-Icer is properly installed and secured, you can now plug the unit into a properly grounded and GFI protected circuit. If a C-10 Thermostat or C-20 Timer/Thermostat Controller was purchased, they can be plugged into the outlet receptacle and the De-Icer plugged into the controller.

STEP SIX (OPTIONAL)

On installations where open water area is required or desired to be limited/controlled, a curtain technique can be used to block the flow of water and restrict the open water area. By draping a canvas tarp as a curtain in the water, you can successfully disrupt the flow of water from the De-Icer. The canvas can be tied above the water level and weighted at the bottom (easiest if you fold the tarp in half and lay a chain in the fold as the weight). The curtain needs to hang into the water a few feet. This curtain will allow you to protect only the area you need. As always, we recommend the ice-free area is well marked.

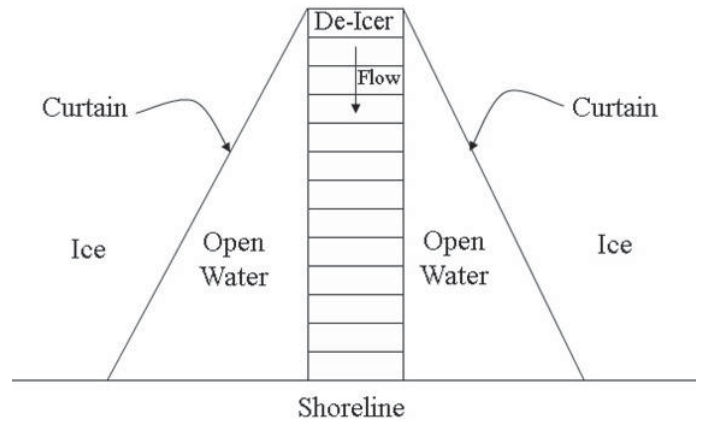

Warranty Policy

Warranty Period:

Models 2400D, 3400D/HD, 4400D/HD- 2 years

Kasco® Marine, Inc. warrants this De-Icer to be free from defects in material or workmanship (except for the ropes, power cord, and propeller) under normal use and service. The Kasco Marine, Inc. obligation under this warranty is limited to replacing or repairing free of charge any defective part within the warranty period. Customer shall pay shipping charges for returning the unit to Kasco or an Authorized Repair Center.

THIS WARRANTY IS IN LIEU OF ANY OTHER WARRANTIES, EXPRESSED OR IMPLIED, AND ANY OTHER OBLIGATION OR LIABILITY WHATEVER ON THE PART OF KASCO MARINE, INC. AND IN NO EVENT SHALL KASCO MARINE, INC. BE LIABLE FOR ANY SPECIAL OR CONSEQUENTIAL DAMAGES.

Warranty is void if:

- The De-Icer is not maintained properly according to the Maintenance Recommendations supplied in this Owners Manual.
- The De-Icer is returned for repair without the power cord or if the unit, control box, or power cord are altered in any way from original shipment. Cuts in the power cord are not covered under warranty.
- The De-Icer is damaged by unauthorized tampering.
- The Sacrificial Zinc Anode around the propeller shaft shows significant deterioration. (The Anode must be inspected periodically and replaced if necessary.)

Warranty Claim Procedure:

The best method for establishing warranty period is by the original receipt. Also, register the Fountain online at: www.de-icer.com.

Once the warranty coverage has been established, the unit may be sent to any Kasco Authorized Repair Center for evaluation and repair. Please call Kasco Marine at 715-262-4488 prior to shipping to receive any updated information and/or Repair Form, then ship to:

Kasco Marine, Inc.
800 Deere Rd.
Prescott, WI 54021
Attn: Repairs

Or call Kasco Marine at 715-262-4488 to locate your nearest Authorized Repair Center. You can also email Kasco at sales@kascomarine.com.

Note: Only complete motor assemblies will be accepted for warranty repair. The power cord and all other components must be returned with the motor as originally assembled. Any missing parts will be replaced at the customer's expense and, if determined to have caused the failure, could void the entire warranty. Some parts are essential for structural support during shipping and others, such as the power cord, are essential to properly diagnose potential causes of failure. It is not necessary to return the C-10, C-20, float, or dock mount with the motor assembly, unless specifically asked to by a Kasco representative.

Please include the Repair Form received from Kasco Marine or your local distributor with the shipment. If no Repair Form is available, include your name and physical address for return delivery of the repaired unit and a daytime phone number and/or e-mail address for correspondence regarding the warranty claim.

Any expedited shipping method for the return of the unit is at the customer's expense. Kasco Marine will return units repaired under warranty at our expense via ground freight within the continental United States.

Other Repairs:

Most failed equipment can be repaired at substantially lower costs than replacement with new. Please ship according to the instructions in the previous section.

Again, it is best to call ahead for updated information and/or Repair Form.

Kasco Marine does estimates on repairs at the request of the customer. The request for estimate should be included in the letter that accompanies the returned unit and must include a daytime phone number and/or e-mail address. Estimate options are as follows:

We will contact the customer with a total after the unit has been evaluated, but before the work is performed. We will repair the unit only if repair costs are under a stated dollar amount. Example: "Please repair if total is under \$150.00 before shipping charges."

All estimates that are rejected for repair will be destroyed unless otherwise directed by the customer. If the customer would like the unit returned, the unit will be restored as closely as possible to the condition in which it was received and shipped at the customer's expense for shipping and handling charges.

Billing:

All non-warranty repairs will be returned to the customer and billed C.O.D. unless otherwise directed. Kasco Marine also accepts Visa and MasterCard credit card payments. Kasco Marine will call for credit card information upon completion of the estimate at the customer's request.

All other warranty and repair inquiries should be directed to Kasco Marine, Inc. at 715-262-4488 or returns@kascomarine.com

Maintenance Recommendations



Under No Circumstances should anyone enter the water while a De-icer is operating. Turn Off and Disconnect electrical power prior to any Maintenance or Servicing

RCD (Residual Current Device) or GFCI are a safety feature that can also alert you to electrical leaks in the equipment. It is extremely important to test the GFCI upon installation, each reinstallation, and monthly thereafter to ensure proper operation. If you have repeat, consistent trips on your ground fault, the equipment should be disconnected and removed from the water. The power cord should be inspected for damage and you should call a Kasco Marine

distributor or representative for further instructions.

If the supply cord becomes damaged, it must be replaced by an authorized service center, or similarly qualified persons in order to avoid a hazard.

OBSERVATION: Operating equipment should be observed on a regular basis (daily, if possible) for any reduction or variation in performance. If a change in performance is observed, the equipment should be disconnected from power and inspected for any material that may have clogged the system or wrapped around the shaft of the motor, especially plastic bags and fishing line. Even though Kasco De-Icers are among the most clog-resistant on the market, it is impossible to protect against all items that can clog equipment and still maintain a flow of water. These materials can be very damaging to the equipment under continued operation and must be removed as soon as possible. **ALWAYS DISCONNECT POWER TO THE UNIT BEFORE ATTEMPTING TO REMOVE CLOGS.**

CLEANING: Equipment should be removed from the water at least once per year to clean the exterior of the system, especially the stainless steel motor housing (can). The motor housing is the surface that dissipates heat into the water and any algae, calcium, etc. build-up will become an insulator that blocks heat transfer. In warmer regions it is recommended that the motor is removed and cleaned at least two to three times per year depending on conditions. In most cases a power washer will be sufficient if the unit and algae are still wet.

SEAL AND OIL REPLACEMENT: This is a sealed motor assembly and seals will wear out over time (similar to brake pads on a car). Replacement of the seals and a change of oil after three years may add longevity to the operation of the motor, saving you the cost of more expensive repairs.

ZINC ANODE: A Sacrificial Zinc Anode is supplied on the shaft of all Kasco De-Icers for protection of the equipment from corrosion and electrolysis. The zinc anode should be replaced if reduced to half the original size or if white in color. Corrosion from electrolysis is more commonly associated with saltwater or brackish water, but as a matter of precaution, it is important to periodically check the

zinc anode in all installations (at least every two to three months).

Seal replacement and all other repair services should be performed by Kasco Marine or a Kasco trained Authorized Repair Center. Please contact your Kasco Marine, Inc. distributor or representative for your nearest Authorized Repair Center.

UNIT STORAGE: When storing units during the offseason, it is important to store them upside down if they are going to be sitting for long periods of time. Units that sit upright on a shelf for many months, or even years have a greater likelihood of seals drying out. Storing upside down will ensure oil is lubricating the seals and prevent drying.

Troubleshooting Tips

Below are some helpful troubleshooting tips. If a problem occurs, please double check the assembly and installation instructions as well as the instructions for the proper control panel. More troubleshooting tips can be found at www.de-icer.com. (Under the Helpful Info tab)

“My De-Icer trips a ground fault interrupter.”

This is the most common symptom of several possible problems. To correctly diagnose the problem, you will need to collect more information. A Ground Fault Interrupter (GFI) that trips can indicate an electrical service problem, water contamination in the unit and/or cord, bad breaker, control box problems, motor problems, etc. Try to find out the answers to these questions before you contact Kasco to narrow down the problem.

- How long does it take to trip the breaker?
- Does it always take the same amount of time to trip?
- How many times has it tripped?
- Has there been any electrical problems in the area recently?

“My De-Icer seems to run slowly.”

This can also be a symptom of several possible problems. There could be an electrical problem where the unit is not getting the proper voltage. This could also indicate a problem with the motor of the unit, which needs to be looked at by an Authorized Repair Center. Check that the unit is receiving the proper voltage, and, if so, contact Kasco for further steps.

Note: If the De-Icer has been stored or exposed to

cold for an extended period without running, it may take a minute for the prop to get to full speed once power is supplied.

“My De-icer hums, but will not start. When I spin the prop with a stick, it starts up.”

This indicated a problem with the Starting Capacitor. Each Kasco De-Icer is equipped with a Starting Capacitor to get the unit going when it is first plugged in. If it is operating, but not spinning and can be started by spinning the prop with a stick, the Starting capacitor needs to be replaced by an Authorized Repair Center.

“My De-icer turns itself off and back on without the timer and without tripping the GFI breaker.”

Each Kasco unit has a Thermal Overload built in that will turn the unit off when it overheats. Once the unit has cooled down, it will start back up. If you are noticing these symptoms, the unit should be unplugged immediately because the Thermal Overload will continue to turn on and off until it burns out and damages the motor. The unit should be unplugged and taken out of the water to find the cause of the problem. The problem could be one of many, such as, low water levels, build-up on the unit to prevent heat dissipation, something inhibiting the free rotation of the shaft, etc. If something is caught in the unit or there is a build-up on the unit, remove the debris and, if caught early enough, the unit should be fine. Contact a Kasco representative before restarting the unit.

“My De-Icer flow seems to fluctuate and/or be less than usual.”

This can occur because of a few different reasons. Most of the time, this symptom is caused from unit being clogged with debris. A mat of weeds, many leaves, plastic bags, etc. can clog up the unit and cause it to be starved of water. If the unit does not have the proper amount of water, the flow or pattern will fluctuate up and down and look sporadic. If you are seeing these symptoms, unplug the unit and clean away the debris that is clogging up the screen. Another possibility if these symptoms are noticed, is a chipped or damaged prop that is causing the unit to wobble and not pump properly. When the unit is unplugged, check the prop for damages and replace if damage is found.

“My C-20 does not seem to be working properly”

Most of the time, a C-20 that is not working

properly is from a setup error. The C-20 Time and Temperature Control must have BOTH the Timer AND Thermostat activated. (The timer must be in an ON position and the outside air temperature must be lower than the setting on the thermostat.) Keep in mind, the thermostat may take a few hours to adjust to the outside temperature. Make sure the C-20 is not in direct sunlight which would heat up the thermostat. If both are activated, the small light in the upper left hand corner of the control box will be lit up. A test that can be done is to put the C-20 in the freezer for a couple hours and then test it. If your outdoor temperature is cold enough, you can set up the C-20 and plug a light into it. Watch it throughout the evening to see if and when the light comes on. If all else fails, please contact Kasco for assistance.

Replacement Parts Diagram

ITEM NO.	PART NO.	DESCRIPTION	QTY.
1A	990275	CORD O RING	1
2	990280	SEALING PLUG	1
3	990281	SEALING ORING	1
4A	243475	ZINC ASSEMBLY (2400 & 3400 MODELS)	1
4B	840475	ZINC ASSEMBLY (4400 & 8400 MODELS)	1
5A	240170	2400 K PROP (2400 MODEL)	1
5B	340125	3400 J PROP (3400 MODEL)	1
5C	440400	4400 M PROP (4400 MODEL)	1
6	261234	HEX NUT	1
7	261240	5/16-18 X 1 HHCS	1
8	990201	CAGE	1
9	261231	FLAT WASHER	2

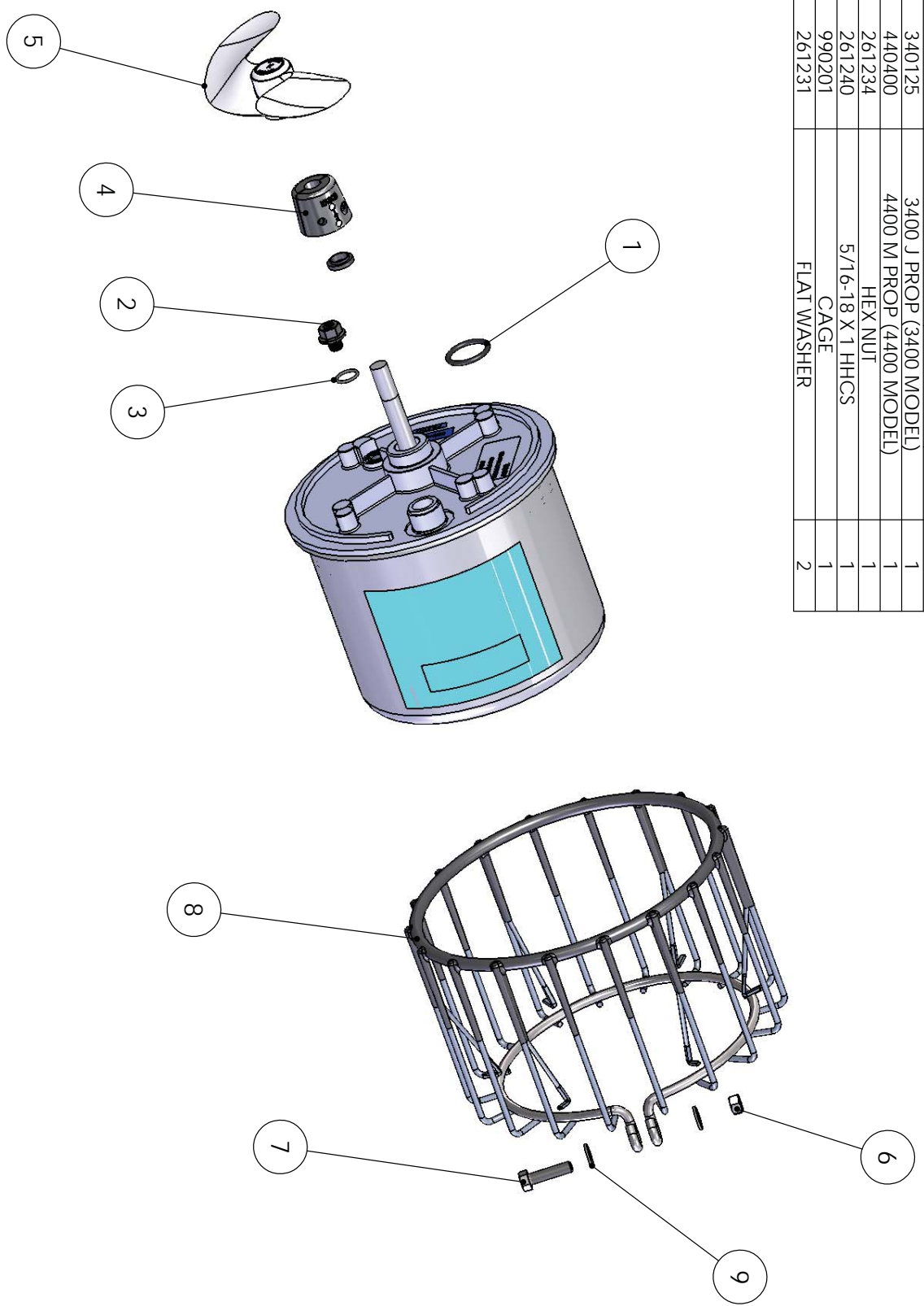

Additional Accessories for Your De-Icer

C-10 Thermostat Control:



The C-10 Thermostat Controller is an inexpensive way to control the operation of your Kasco De-icer by using air temperature. The C-10 plugs into a standard 120V outlet and allows you to set an air temperature setting to turn the de-icer on when the temperature drops below that setting, allowing you to save money on electrical bills.

Universal Dock or Piling Mount:



Kasco's heavy duty dock or piling mount is made from corrosion protected steel and stainless steel. This dock mount can be used with any of our de-icer units. Users supply their own 10 foot 1" O.D. pipe. Includes a Qwiklock handle for easy installation and adjustments

C-20 Timer and Temperature Control:



Kasco's C-20 further maximizes energy conservation from the C-10 with the added timer feature. The C-20 will only operate your De-icer when both the timer and thermostat are activated.

Horizontal Float:

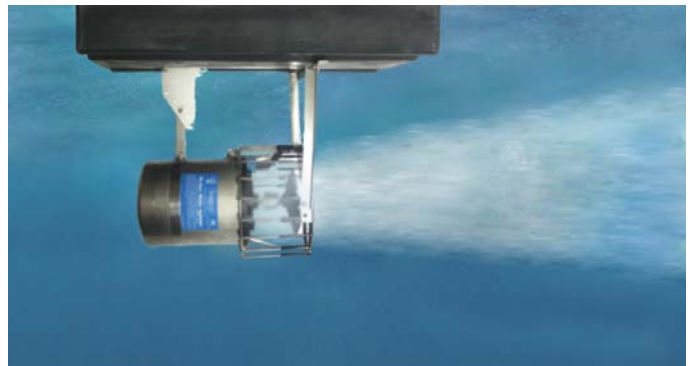

The horizontal float is an easy to assemble kit consisting of stainless steel components and a flotation block. The de-icer is mounted at an angle just below the float producing an elongated pattern of agitated water and is well suited for shallow water operation.

Visit www.de-icer.com for more information on these accessories for your de-icer.



800 Deere Rd.
 Prescott, WI 54021
 Phone: 715-262-4488 - Fax: 715-262-4487
 www.KascoMarine.com Sales@KascoMarine.com

Customer Repair Form

*** Important Reminders ***

- All repairs sent in **MUST** be accompanied by a copy of this completed sheet!
- Routine maintenance consists of checking the zinc anode regularly and replacing if necessary, keeping the unit clean, keeping the stainless steel can clean, and having the seals and oil replaced every 3 years depending on use.
- Address your Repair to Kasco Marine, Attn: Repairs (or to your Authorized Repair Center).
- Shipping to Kasco or an Authorized Repair Center is paid for by the customer.
- You must include the power cord and cage assembly with each unit sent in for repair to be considered for warranty and for proper repair and shipping protection!
- Do not ship the float and/or control box with the unit for repair, unless otherwise instructed.

Today's Date: _____

Customer Information

Name: _____

Phone Number: _____

Address: _____

Alternate Number: _____

City: _____

Email Address: _____

State: _____

Zip Code: _____

Unit Information:

Model # (Ex. 3400D): _____

Serial # (Ex. 7001D341025): _____

Date Purchased: _____

Purchased From: _____

Earliest Date of Problem: _____

Description of Problem:

Comments:

Registration Information

Please register your fountain online at:

www.kascomarine.com

Also fill in the information below and keep for your records.

Model # (Ex. 3400D) _____

Serial # (Ex. 8001D341725) _____

Purchase Date: _____

Purchased From: _____

Registration Date: _____



Kasco Marine, Inc.
800 Deere Rd.
Prescott, WI 54021

Phone (715) 262-4488 • Fax (715) 262-4487

www.kascomarine.com • www.de-icer.com • sales@kascomarine.com